

PR



2261 Усилитель тензодатчиков, mV-усилитель

Руководство по эксплуатации

Архангельск (8182)63-90-72
Астана (7172)727-132
Астрахань (8512)99-46-04
Барнаул (3852)73-04-60
Белгород (4722)40-23-64
Брянск (4832)59-03-52
Владивосток (423)249-28-31
Волгоград (844)278-03-48
Вологда (8172)26-41-59
Воронеж (473)204-51-73
Екатеринбург (343)384-55-89
Иваново (4932)77-34-06
Ижевск (3412)26-03-58
Казань (843)206-01-48

Калининград (4012)72-03-81
Калуга (4842)92-23-67
Кемерово (3842)65-04-62
Киров (8332)68-02-04
Краснодар (861)203-40-90
Красноярск (391)204-63-61
Курск (4712)77-13-04
Липецк (4742)52-20-81
Магнитогорск (3519)55-03-13
Москва (495)268-04-70
Мурманск (8152)59-64-93
Набережные Челны (8552)20-53-41
Нижний Новгород (831)429-08-12
Новокузнецк (3843)20-46-81

Новосибирск (383)227-86-73
Омск (3812)21-46-40
Орел (4862)44-53-42
Оренбург (3532)37-68-04
Пенза (8412)22-31-16
Пермь (342)205-81-47
Ростов-на-Дону (863)308-18-15
Рязань (4912)46-61-64
Самара (846)206-03-16
Санкт-Петербург (812)309-46-40
Саратов (845)249-38-78
Севастополь (8692)22-31-93
Симферополь (3652)67-13-56
Смоленск (4812)29-41-54

Сочи (862)225-72-31
Ставрополь (8652)20-65-13
Сургут (3462)77-98-35
Тверь (4822)63-31-35
Томск (3822)98-41-53
Тула (4872)74-02-29
Тюмень (3452)66-21-18
Ульяновск (8422)24-23-59
Уфа (347)229-48-12
Хабаровск (4212)92-98-04
Челябинск (351)202-03-61
Череповец (8202)49-02-64
Ярославль (4852)69-52-93

mV TRANSMITTER

Type 2261

CONTENTS

| | |
|--|----|
| Declaration of Conformity | 18 |
| Applications | 19 |
| Technical characteristics | 20 |
| Inputs | 20 |
| Taring | 20 |
| Standard current / voltage output | 20 |
| Front error LED | 21 |
| Transducer supply | 21 |
| Sense | 21 |
| Electrical specifications | 21 |
| Order | 24 |
| Block diagram | 24 |
| Hardware programming | 24 |
| Routing diagram | 26 |
| Programming / operating the function keys | 28 |
| Description of functions (application selection) | 31 |

DECLARATION OF CONFORMITY

mV TRANSMITTER

As manufacturer

PR electronics A/S

hereby declares that the following product:

Type: 2261

Name: mV transmitter

is in conformity with the following directives and standards:

The EMC Directive 2004/108/EC and later amendments

EN 61326-1

For specification of the acceptable EMC performance level, refer to the electrical specifications for the module.

- *Load cell amplifier*
- *mV to current / voltage conversion*
- *Front-programmable / LED display*
- *Relative calibration of input span*
- *NPN / PNP input for external taring*
- *Supply for standard transducers*

| | |
|---------------------------|------------------------------|
| SUPPLY: | |
| Supply voltage: | 24 VDC |
| Transducer supply: | 5...13 VDC |
| INPUT RANGE: | |
| Measurement range: | -40...100 mV |
| Taring input: | PNP / NPN / front key |
| OUTPUT RANGE: | |
| Current output: | 0...20 mA |
| Voltage output: | 0...10 V |

APPLICATIONS:

Tank filling and draining.
Weighing with a taring function.
Measurement of cable tensile force.
Level control.
Signal conversion / amplification.

The 2261 converts bipolar mV signals from transducers supplied directly by the module to standard current / voltage signals. The 2261 is suitable for load cell applications. By way of the relative calibration function the scale can be tared, i.e. 0 and 100% calibrated without the need of the equivalent load. By way of the taring function the measured range is set to either 0% when filling or 100% when draining.



Kim Rasmussen
Manufacturer's signature

TECHNICAL CHARACTERISTICS:

In general:

The 2261 is microprocessor-controlled and basic-calibrated meaning that input and output can be programmed acc. to the requested signal range without any readjustment. This guarantees high accuracy and flexibility.

The user interface consists of a 3-digit display and 3 front function keys which are used for taring or change of input / output signal range.

INPUTS:

Analogue input:

The analogue input can be programmed for voltage in the range -40...100 mVDC with a min. span of 10 mV and max. offset of 70% of max. mV value.

A percentage overrange of the selected measurement range can be defined, thereby making the unit react to an mV input outside the selected 0 and 100% range. The display will show the input percentage.

The output must be scaled in such a way that the selected overrange is within the allowed output signal range.

Digital input:

The digital signal can be selected as either NPN (short circuit to gnd.), or PNP (+24 VDC).

TARING:

Taring can either be by way of the digital input or from the front.

At 0% taring, the analogue input will show 0% after taring. At 100% taring, the analogue input will show 100% after taring, corresponding to tara + net weight = gross weight.

The analogue input span is not changed but is kept relative to the new offset value.

The taring function can be disabled at the front.

STANDARD CURRENT / VOLTAGE OUTPUT:

The analogue output can be programmed to current in the range 0...20 mA or voltage in the range 0...10 VDC with a min. span of 5 mA or 250 mVDC with max. offset of 50% of the selected max. value.

By short-circuiting pins 2 and 3, the voltage signal is available between pins 2 and 1.

For voltage signals in the range 0...1 VDC, a 50 Ω shunt (DP 2-1) is applied; in the range 0...10 VDC, a 500 Ω shunt (DP 2-2) is applied.

When both voltage and current signals are used simultaneously, the mA loop must go to ground through the internal shunt.

FRONT ERROR LED:

At an incorrect output, the red LED will flash, e.g. at overrange saturation.

TRANSDUCER SUPPLY:

Front-programmable to 5...13 VDC. The supply is short circuit-protected and has a max. load of 230 mA (e.g. 6 parallel 350 Ω load cells).

SENSE:

When the transducer supply is applied, the sense input can be used for compensation for cable resistance to the transducer.

ELECTRICAL SPECIFICATIONS:

Specifications range:

-20°C to +60°C

Common specifications:

| | |
|--------------------------------------|-----------------------------|
| Supply voltage..... | 19.2...28.8 VDC |
| Internal consumption | 2.2 W |
| Max. consumption..... | 7.2 W |
| Signal / noise ratio | Min. 60 dB |
| Signal dynamics, input | 17 bit |
| Signal dynamics, output | 16 bit |
| Updating time..... | 20 ms |
| Response time, programmable | 0.06...999 s |
| Calibration temperature..... | 20...28°C |
| Temperature coefficient..... | < $\pm 0.01\%$ of span / °C |
| Linearity error | $\leq \pm 0.1\%$ of span |
| Effect of supply voltage change..... | < $\pm 0.002\%$ of span/ %V |

Auxiliary voltage:

| | |
|------------------------|------------|
| Transducer supply..... | 5...13 VDC |
| Load (max.)..... | 230 mA |

EMC immunity influence

| |
|-----------------------|
| < $\pm 0.5\%$ of span |
|-----------------------|

| | |
|-----------------------------|-----------------------|
| Relative air humidity | < 95% RH (non-cond.) |
| Dimensions (HxWxD)..... | 80.5 x 35.5 x 84.5 mm |
| Protection degree..... | IP50 |
| Weight | 130 g |

Electrical specifications - Input:**mV input:**

| | |
|--|---|
| Measurement range | -40...100 mV |
| Min. measurement range (span)..... | 10 mV |
| Max. offset..... | 70% of selected max. value |
| Input in relation to supply gnd..... | > -5 V and < +10 V |
| Max. cable resistance per wire..... | 15 Ω |
| Suppression of transducer cable resistance..... | > 300 |
| Input resistance..... | > 10 M Ω |
| Overrange..... | 0...999% of selected measurement range |

Digital input:

| | |
|-----------------------|--------------------------|
| NPN | Pull up 24 VDC / 6.9 mA |
| PNP | Pull down 0 VDC / 6.9 mA |
| Trig level low..... | < 6 VDC |
| Trig level high | > 10.5 VDC |
| Pulse width..... | > 30 ms |

Electrical specifications - Output:**Current output:**

| | |
|-------------------------------|-------------------------------------|
| Signal range | 0...20 mA |
| Min. signal range (span)..... | 5 mA |
| Max. offset..... | 50% of selected max. value |
| Load (max.)..... | 20 mA / 600 Ω / 12 VDC |
| Load stability | < $\pm 0.01\%$ of span/100 Ω |
| Current limit..... | < 23 mA |

Voltage output through internal shunt:

| | |
|-------------------------------|----------------------------|
| Signal range | 0...10 VDC |
| Min. signal range (span)..... | 250 mVDC |
| Max. offset..... | 50% of selected max. value |
| Load (min.)..... | 500 k Ω |
| Voltage limit..... | < 11.5 VDC |

GOST R approval:

VNIIM

| | |
|---|-----------------|
| Observed authority requirements: | Standard |
| EMC 2004/108/EC | EN 61326-1 |

Of span = Of the presently selected range

ORDER: 2261

BLOCK DIAGRAM:

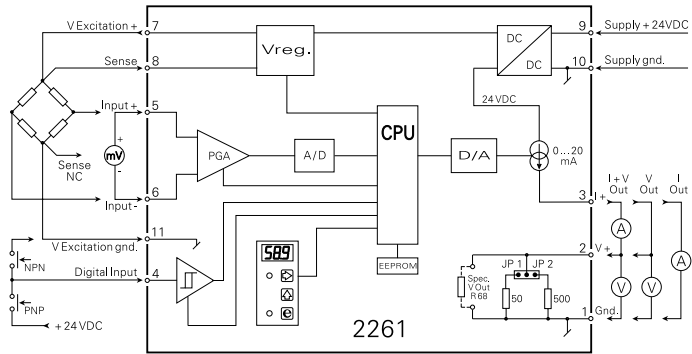

HARDWARE PROGRAMMING:

| JP1 | JP2 | Output range | MENU 4.3 |
|-----|-----|--------------|----------|
| OFF | OFF | 0...10 mA | 001 |
| | | 0...20 mA | 002 |
| ON | OFF | 0...500 mV | 003 |
| | | 0...1000 mV | 004 |
| OFF | ON | 0...5 V | 005 |
| | | 0...10 V | 006 |

Routing diagram

If no buttons are pressed for a period of 2 minutes, display returns to stage 0.0

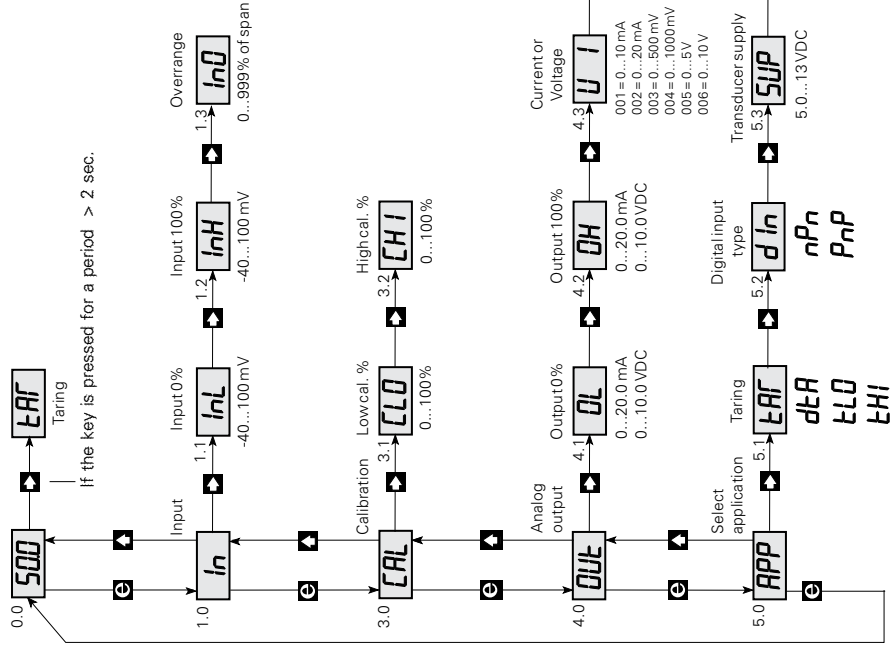

Programming

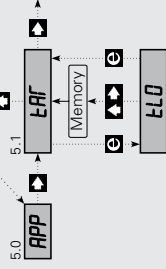

- Go to entry menu/Leave menu without changes
- Next digit or point
- Change of parameter
- Press and hold then press to store changes

- Response time **FEP** (0.06...999 s)
- Current or Voltage **U1** (001=0...10 mA, 002=0...20 mA, 003=0...500 mV, 004=0...1000 mV, 005=0...5 V, 006=0...10 V)
- Program access **PR5** (0...999)
- Transducer supply **SUP** (5.0...13 VDC)
- Digital input type **dIn** (nPN, PNP)
- Frequency suppression **FF9** (50 Hz, 60 Hz)
- Password code **040** = enable change in all stages
- = disable change

PROGRAMMING / OPERATING THE FUNCTION KEYS

GENERAL:

The programming is menu-controlled. The main menus are numbered in level 0 (X.0), and the submenus are numbered in level 1 (X.1 - X.5).

Each submenu has an accompanying entry menu. The menus are structured in such a way that the menus most frequently used are closer to the default menu 0.0.

Please note that programming is only possible when submenu 5.4 PAS has the value 040.

Main, sub, and entry menus are selected by the 3 function keys $\left[\left[\left[\right] \right] \right]$ as outlined in the routing diagram. Activating $\left[\left[\left[\right] \right] \right]$ in the submenus will display the set value in the entry menu.

In entry menus, the digit that can be changed will flash. Active digit position is shifted by the $\left[\left[\left[\right] \right] \right]$ key and changed by the $\left[\left[\left[\right] \right] \right]$ key. When the decimal point flashes, its position can be shifted by the $\left[\left[\left[\right] \right] \right]$ key.

In entry menus with fixed parameters, you switch between the parameters by the $\left[\left[\left[\right] \right] \right]$ key.

Store by first activating the $\left[\left[\left[\right] \right] \right]$ key and then the $\left[\left[\left[\right] \right] \right]$ key simultaneously.

Press $\left[\left[\left[\right] \right] \right]$ to return to the previous menu without changing the parameter.

0.0 DEFAULT - The input value is displayed in % of the input span.

At power ON, or if no keys have been activated for a period of 2 minutes, the display returns to default.

$\left[\left[\left[\right] \right] \right]$ tAR - Taring

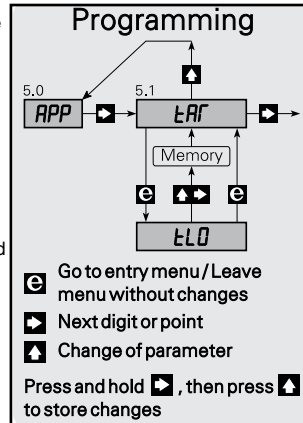

When submenu 5.1 has been selected for {tLO or tHI}, activating the $\left[\left[\left[\right] \right] \right]$ key for more than 2 s will tare the input value to the value it had when activated. The input span is not affected but is kept relative to the new offset value.

1.0 In - SETTING OF INPUT SPAN

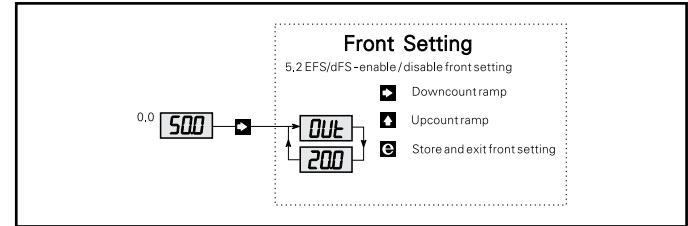

1.1 InL - Setting of 0% input value

Valid selections are -40...100 mV.

1.2 InH - Setting of 100% input value

Valid selections are -40...100 mV.

1.3 InO - Setting of overrange

The analogue output follows the set input span on a linear basis {1.1 - InL and 1.2 - InH} with a limit at 20.5 mA (normally approx. 103% input span).

When the input signal is < or > the set input span, the display will track this and show -xx or xxx% until the input begins to limit.

The overrange is set in % of the input span and guarantees that the input does not begin to limit within the percentage overrange, neither below nor above the set input span, provided that the input span \pm overrange is within the signal range -40 to 100 mV.

Setting the overrange does not affect the analogue output.

If the overrange measurement is to be included in the analogue output signal, the output signal for the set input span must be selected to provide room for the overrange within the signal range of the output (0...20 mA / 0...10 VDC).

Example:

A signal of 5...15 mV corresponds to a weight of 0...1000 kilo.

It must be possible to detect a 50% overrange of the scale on the analogue output of the mV transmitter at the same time as the display shows 150%.

The following settings will result in the requested function with an output signal of 4...19.9 mA:

Input: InL = 5.0, InH = 15.0, InO = 50.0

Output: OL = 4.0, OH = 14.6, UI = 002

Please note that the output span has been set to (14.6 mA - 4.0 mA) = 10.6 mA which, with an addition of 50%, will result in a span of (10.6 + (10.6 * 50/100)) = 15.9 mA.

3.0 CAL - SETTING OF CALIBRATION VALUES

The calibration function is a relative calibration, i.e. the percentage input value for the low calibration must be entered in submenu 3.1 {CLO - Calibration Low}, and the percentage input value for the high calibration must be entered in submenu 3.2 {CHI - Calibration High}. The entered percentages are used for calculating the actual input span.

When {CHI - Calibration High} is activated, the calculation is made using the percentages in {CLO} and {CHI}.

3.1 CLO - Setting of low calibration value

Key **[F2]**. Enter the calibration value by the **[F1]** and **[F3]** keys.

Connect the low calibration signal to the input. Activate the **[F1]** and **[F3]** keys simultaneously.

3.2 CHI - Setting of high calibration value

Key **[F2]**. Enter the calibration value by the **[F1]** and **[F3]** keys.

Connect the high calibration signal to the input. Activate the **[F1]** and **[F3]** keys simultaneously.

The input span is now calculated using the entered calibration values. The mV values are read from the submenus {1.1 - InL and 1.2 - InH}.

4.0 Out - SETTING OF ANALOGUE OUTPUT

4.1 OL - Low - 0% setting of analogue output

Valid selections are current in the range 0.0...20.0 mA or voltage in the range 0.0...10.0 VDC.

4.2 OH - High - 100% setting of analogue output

Valid selections are current in the range 0.0...20.0 mA or voltage in the range 0.0...10.0 VDC.

4.3 UI - Selection of current or voltage output

See the hardware programming for correct jumper setting. Possible selections are:

001 = Current output in the range 0...10 mA

002 = Current output in the range 0...20 mA

003 = Voltage output in the range 0...500 mV

004 = Voltage output in the range 0...1000 mV

005 = Voltage output in the range 0...5 V

006 = Voltage output in the range 0...10 V

4.4 rEP - Setting of response time

Valid selections are 0.0...999 s. If the set response time is < 0.06 s, the response time will be 0.06 s.

5.0 APP - APPLICATION SELECTION

5.1 tAR - Selection of taring type

Possible selections are tLO - 0% taring enable, tHI - 100% taring enable, or dtA - taring disabled.

If tLO is selected, activating the **[F2]** key for more than 2 s or activating the digital input will tare the input signal to 0%.

If tHI is selected, activating **[F2]** for more than 2 s or activating the digital input will tare the input signal to 100% (max.).

The 2 types of taring can be used for filling or emptying respectively.

If a 0% (tLO) taring is selected, the analogue input will show 0% after taring. If a 100% (tHI) taring is selected, the input will show 100% after

taring corresponding to tara + net weight = gross weight.

Taring is either from the digital input or from front.

5.2 dIN - Selection of digital input type

Possible selections are:



PnP = mechanical contact or open collector transistor connected to +24 VDC.



nPn = mechanical contact or open collector transistor connected to gnd.

5.3 SUP - Setting of supply voltage for transducer

Valid selections are 5.0...13 VDC.

5.4 PAS - Setting of password

Key . When the password is 040, changes can be made in all menu points. When the password is <> 040, programming is blocked in all menu points, but access is open for reading the settings. Enter the password by the  and  keys.

When the password is correct, activate  and  simultaneously. Valid selections are 0...999.

5.5 Frq - Selection of common mode frequency suppression

Possible selections are 50 or 60 Hz.

По вопросам продажи и поддержки обращайтесь:

Архангельск (8182)63-90-72
Астана (7172)727-132
Астрахань (8512)99-46-04
Барнаул (3852)73-04-60
Белгород (4722)40-23-64
Брянск (4832)59-03-52
Владивосток (423)249-28-31
Волгоград (844)278-03-48
Вологда (8172)26-41-59
Воронеж (473)204-51-73
Екатеринбург (343)384-55-89
Иваново (4932)77-34-06
Ижевск (3412)26-03-58
Казань (843)206-01-48

Калининград (4012)72-03-81
Калуга (4842)92-23-67
Кемерово (3842)65-04-62
Киров (8332)68-02-04
Краснодар (861)203-40-90
Красноярск (391)204-63-61
Курск (4712)77-13-04
Липецк (4742)52-20-81
Магнитогорск (3519)55-03-13
Москва (495)268-04-70
Мурманск (8152)59-64-93
Набережные Челны (8552)20-53-41
Нижегород (831)429-08-12
Новокузнецк (3843)20-46-81

Новосибирск (383)227-86-73
Омск (3812)21-46-40
Орел (4862)44-53-42
Оренбург (3532)37-68-04
Пенза (8412)22-31-16
Пермь (342)205-81-47
Ростов-на-Дону (863)308-18-15
Рязань (4912)46-61-64
Самара (846)206-03-16
Санкт-Петербург (812)309-46-40
Саратов (845)249-38-78
Севастополь (8692)22-31-93
Симферополь (3652)67-13-56
Смоленск (4812)29-41-54

Сочи (862)225-72-31
Ставрополь (8652)20-65-13
Сургут (3462)77-98-35
Тверь (4822)63-31-35
Томск (3822)98-41-53
Тула (4872)74-02-29
Тюмень (3452)66-21-18
Ульяновск (8422)24-23-59
Уфа (347)229-48-12
Хабаровск (4212)92-98-04
Челябинск (351)202-03-61
Череповец (8202)49-02-64
Ярославль (4852)69-52-93

Единый адрес для всех регионов: pcn@nt-rt.ru || www.prelectronics.nt-rt.ru

