

PR



2281 Регулятор линейного измерения вверх-вниз, передатчик положения через 2-х фазный преобразователь

Руководство по эксплуатации

Архангельск (8182)63-90-72
Астана (7172)727-132
Астрахань (8512)99-46-04
Барнаул (3852)73-04-60
Белгород (4722)40-23-64
Брянск (4832)59-03-52
Владивосток (423)249-28-31
Волгоград (844)278-03-48
Вологда (8172)26-41-59
Воронеж (473)204-51-73
Екатеринбург (343)384-55-89
Иваново (4932)77-34-06
Ижевск (3412)26-03-58
Казань (843)206-01-48

Калининград (4012)72-03-81
Калуга (4842)92-23-67
Кемерово (3842)65-04-62
Киров (8332)68-02-04
Краснодар (861)203-40-90
Красноярск (391)204-63-61
Курск (4712)77-13-04
Липецк (4742)52-20-81
Магнитогорск (3519)55-03-13
Москва (495)268-04-70
Мурманск (8152)59-64-93
Набережные Челны (8552)20-53-41
Нижний Новгород (831)429-08-12
Новокузнецк (3843)20-46-81

Новосибирск (383)227-86-73
Омск (3812)21-46-40
Орел (4862)44-53-42
Оренбург (3532)37-68-04
Пенза (8412)22-31-16
Пермь (342)205-81-47
Ростов-на-Дону (863)308-18-15
Рязань (4912)46-61-64
Самара (846)206-03-16
Санкт-Петербург (812)309-46-40
Саратов (845)249-38-78
Севастополь (8692)22-31-93
Симферополь (3652)67-13-56
Смоленск (4812)29-41-54

Сочи (862)225-72-31
Ставрополь (8652)20-65-13
Сургут (3462)77-98-35
Тверь (4822)63-31-35
Томск (3822)98-41-53
Тула (4872)74-02-29
Тюмень (3452)66-21-18
Ульяновск (8422)24-23-59
Уфа (347)229-48-12
Хабаровск (4212)92-98-04
Челябинск (351)202-03-61
Череповец (8202)49-02-64
Ярославль (4852)69-52-93

RAMP GENERATOR

Type 2281

CONTENTS

Declaration of Conformity	18
Applications.	19
Technical characteristics	19
Inputs.	19
Functions:	
Ramp generator with internal time measurement.	20
Ramp generator with external pulses	20
Ramp generator for 2-phase encoder	20
Output	20
Electrical specifications.	21
Order	23
Block diagram	23
Hardware programming	23
Routing diagram	24
Programming / operating the function keys	26
Description of functions (selection of application)	29

DECLARATION OF CONFORMITY

As manufacturer

PR electronics A/S

hereby declares that the following product:

Type: 2281

Name: Ramp generator

is in conformity with the following directives and standards:

The EMC directive 2004/108/EC and later amendments

EN 61326-1

For specification of the acceptable EMC performance level, refer to the electrical specifications for the module.



Peter Rasmussen
Manufacturer's signature

RAMP GENERATOR 2281

- Multiple functions
- Programmable from front
- 3-digit LED display
- NPN and PNP inputs
- Internal ramp time or external pulses
- Reset or preset function

APPLICATIONS:

To convert digital signals to a time-controlled analogue signal with either internally entered up/down time or with external pulses for up/down function. Can convert digital outputs to analogue outputs. By connection of a 2-phase encoder as up/down pulse generator the pulses will be converted to an analogue position signal. Especially suitable in applications where easy 11-pole relay socket mounting is required for instance in a panel. Possibility of readout of the analogue value of the output through the built-in display.

TECHNICAL CHARACTERISTICS:

GENERAL:

The 2281 is microprocessor-controlled and basic-calibrated. This means that the input and output can be programmed acc. to the requested signal range without any readjustment. Thereby a high degree of accuracy and flexibility are ensured. The user interface consists of a 3-digit display and 3 function keys in the front. The interface is used to change a function, ramp time or an output signal range.

INPUTS:

6 digital inputs make it possible to choose reset, up/down functions as either NPN inputs (short circuit to gnd.) or as PNP input (+ 24 VDC). The trigger level is typically 8 VDC with a pull up/down resistance of 3.5 k Ω corresponding to a load current of 6.9 mA. Via an analogue switch the up and down inputs can be switched between input filters for a pulse length > 10 ms or > 0.5 ms. The chosen filter is the same for all up/down inputs. The 10 ms filter is used for elimination of contact-bounce. The reset inputs have a filter for pulse lengths > 30 ms. The arrow keys can be selected to work in parallel with the digital up and down inputs.

FUNCTIONS:

RAMP GENERATOR WITH INTERNAL TIME MEASUREMENT:

Up ramp and down ramp can be set separately in the time span 0.1...999999 s. Reset can be chosen to preset at any value between 0 and 100% output signal. The up/down time measurement starts when the time constant of the selected filter has been exceeded.

If the up/down inputs are activated simultaneously, both ramps will be activated and the outputs rise/fall with the difference of the times.

RAMP GENERATOR WITH EXTERNAL PULSES:

Up ramp and down ramp can be adjusted separately with a number of pulses between 1 and 15,615,744. The entered number of pulses (max. 60999) are multiplied by the prescaler which can assume values between 1 and 256. Reset can be chosen to preset at any value between 0% and 100% output signal. The pulse length must be longer than the time constant of the selected filter. If the up/down inputs are activated simultaneously both input pulses will be scanned and the output will rise/fall with the difference of the pulses. In case of supply drop-out the position will be remembered when the prescaler is 1.

RAMP GENERATOR FOR 2-PHASE ENCODER:

The ramp pulses are set to a value between 1 and 15,615,744. The entered number of pulses (max. 60999) is multiplied by the prescaler which can assume values between 1 and 256. The pulse length must be longer than the time constant of the selected filter.

When the encoder is turned in one direction the output rises compared to the set number and pulses, when the encoder is turned in the opposite direction the output falls proportionally.

The reset can be chosen to preset at any value between 0% and 100% output signal. By activating reset for instance in a 50% position an auto-calibration of the measuring system is obtained. In case of supply drop-out the position will be remembered when the prescaler is 1.

OUTPUT:

Analogue standard current output of 0/4...20 mA or, with JP3 off, 0/2...10 mA. The output span can be set to any value within the standard ranges with a max. offset of 50% of the max. value and a minimum span of 5 mA. Restart after a supply drop-out can be chosen to generate either the reset value or the value which the output had just before the supply drop-out. Maximum load is 600 Ω / 12 VDC. By short-circuit of pins 3 and 2 the output current is converted to a standard voltage of 0/0.2...1 VDC, 0/2...10 VDC or special VDC dependent on the size of R65. The voltage signal is available between pins 2 and 1.

See hardware programming for correct choice.

An overrange can be defined thereby enabling the output to exceed the selected signal range by $\pm 3\%$ within the limit of 0...20.5 mA.

ELECTRICAL SPECIFICATIONS:

Specifications range:

-20°C to +60°C

Common specifications:

Supply voltage	19.2...28.8 VDC
Internal consumption	2.4 W
Max. consumption	2.7 W
Signal / noise ratio	Min. 60 dB
Up ramp time	0.1...999999 s
Down ramp time	0.1...999999 s
External pulses	1...15,615,744
Response time	< 60 ms
Signal dynamics, output	16 bit
Calibration temperature	20...28°C
Temperature coefficient	< $\pm 0.01\%$ of span/°C
Linearity error	< $\pm 0.1\%$ of span
Effect of supply voltage change	< $\pm 0.005\%$ of span/%V

EMC immunity influence < $\pm 0.5\%$

Relative air humidity	< 95% RH (non-cond.)
Dimensions (HxWxD)	84.5 x 35.5 x 80.5 mm (excl. pins)
Protection degree	IP50
Weight	120 g

Electrical specifications - INPUT:

Digital input:

Up / down inputs:

NPN	Pull up 24 VDC / 6.9 mA
PNP	Pull down 0 VDC / 6.9 mA
Pulse width, programmable	>10 ms / > 0.5 ms
Input frequency (max.)	50 Hz / 1 kHz

Reset inputs:

NPN Pull up 24 VDC / 6.9 mA
 PNP Pull down 0 VDC / 6.9 mA
 Pulse width > 30 ms
 Input frequency (max.) 16 Hz

Electrical specifications - output:

Current output:

Signal range 0...20 mA
 Min. signal range (span) 5 mA
 Max. offset 50% of selected max. value
 Load (max.) 20 mA / 600 Ω / 12 VDC
 Load stability < ±0.01% of span/100 Ω
 Current limit 20.5 mA

Voltage input via an internal shunt:

Signal range 0...10 VDC
 Min. signal range (span) 250 mV
 Max. offset 50% of selected max. value
 Load (min.) 500 kΩ
 Voltage limit 10.25 VDC

GOST R approval:

VNIIM, Cert. no. Ross DK.ME48.V01899

Observed authority requirements:

EMC 2004/108/EC

Emission and immunity EN 61326-1

Of span = Of the presently selected range

ORDER: 2281

BLOCK DIAGRAM:

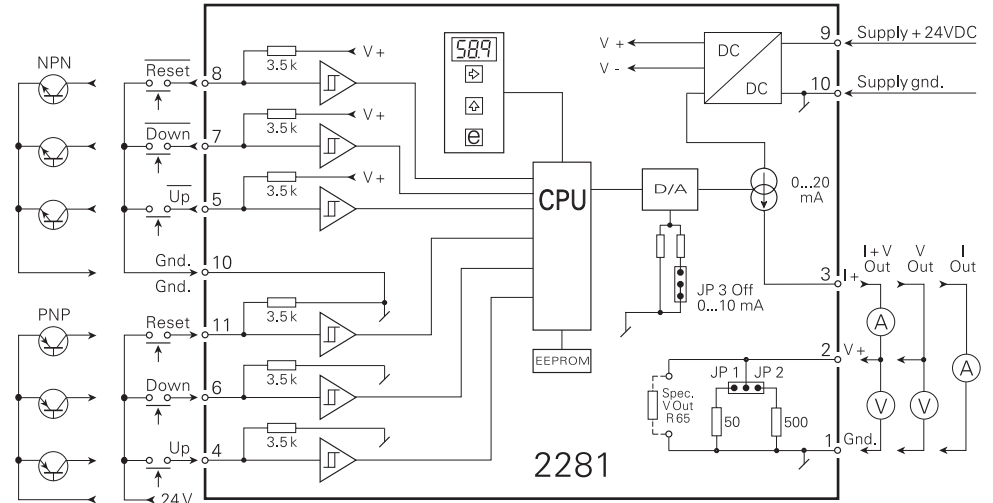

HARDWARE PROGRAMMING:

JP1	JP2	JP3	Output	MENU 4.3
OFF	OFF	OFF	0...10 mA	1
		ON	0...20 mA	2
ON	OFF	OFF	0...500 mV	3
		ON	0...1000 mV	4
OFF	ON	OFF	0...5 V	5
		ON	0...10 V	6

Routing diagram

If no buttons are pressed for a period of 2 minutes, display returns to stage 0.0

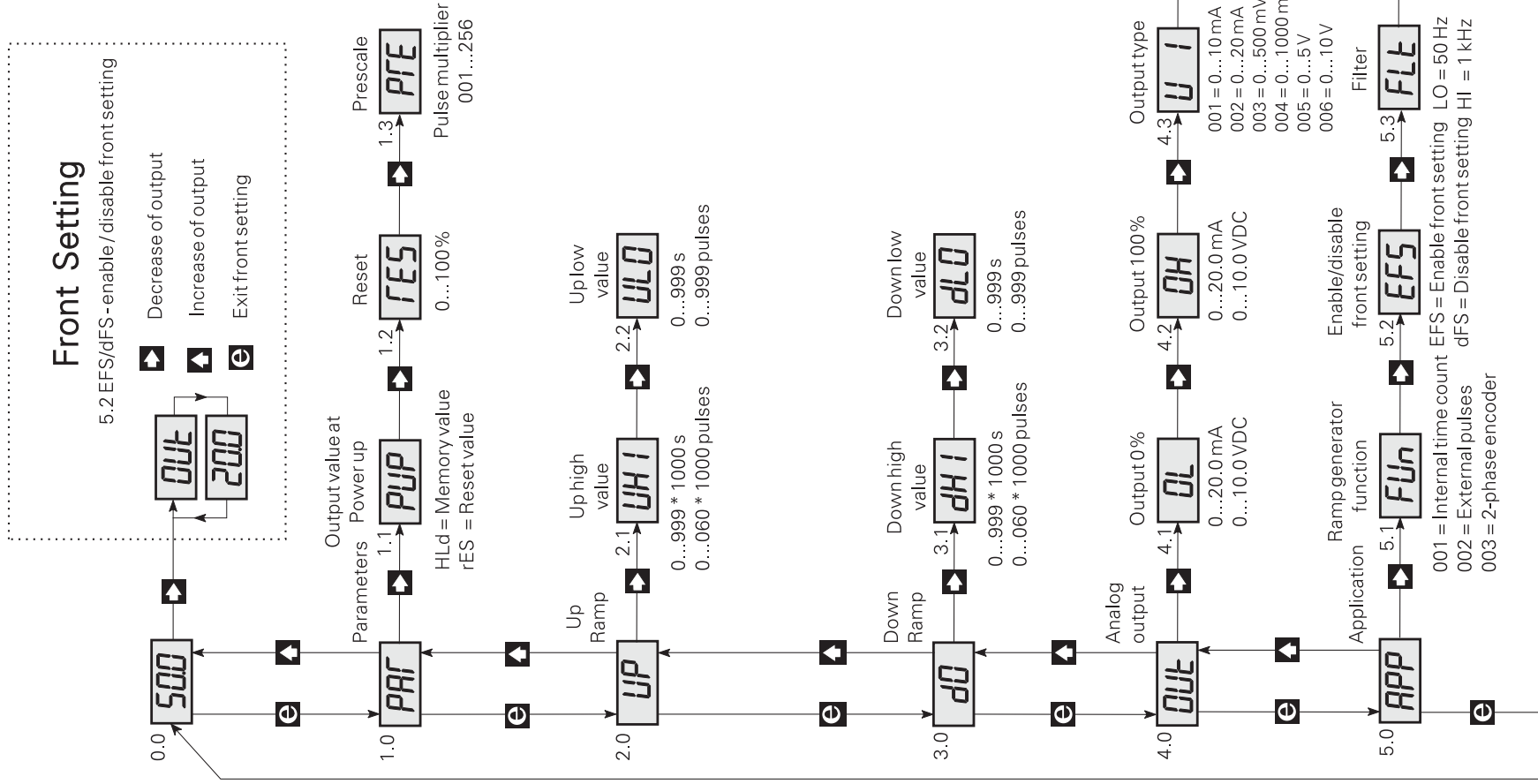

Programming

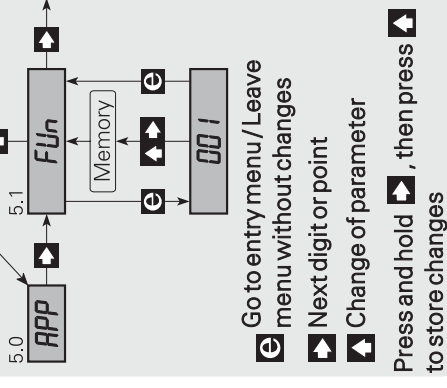

PROGRAMMING / OPERATING THE FUNCTION KEYS

DOCUMENTATION FOR ROUTING DIAGRAM

GENERAL:

The programming is menu-controlled. The main menus are numbered in level 0 (x.0), and the submenus are numbered in level 1 (x.1 to x.5). Each submenu has an accompanying entry menu. The menus are structured in such a way that the menus most frequently used are closer to the default menu 0.0. Please note that programming is only possible when submenu 5.4 PAS has the value 040.

Menus and submenus are selected by the 3 function keys **e**, **▶**, and **▲** as outlined in the routing diagram.

Activating **e** will display the current value. In entry menus, the digit that can be changed will flash.

Active digit position is shifted by the **▶** key, and the value is changed by the **▲** key. When the decimal point flashes, its position can be changed by the **▶** key.

In parameter selection menus you switch between the parameters by the **▲** key.

Store by first activating **▶** and then **▲** simultaneously.

To return to the previous menu without changing the parameters - activate **e**. If a non-valid value is entered, the display will show Err for 2 s and then return to the entry menu with the initial parameters.

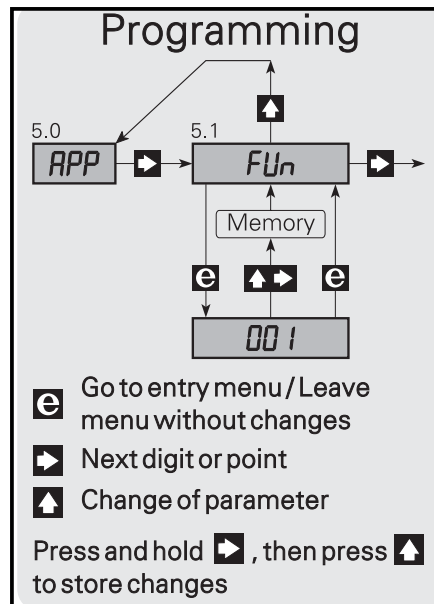

0.0 DEFAULT - THE OUTPUT VALUE IS DISPLAYED IN %.

The display returns to default at power ON, or if no keys have been activated for a period of 2 minutes.

▶ FRONT SETTING - MANUAL OPERATION OF UP RAMPS OR DOWN RAMPS.

When menu 5.2 has been selected as EFS (Enable Front Setting), you can ramp up or down by way of the Front Setting function. In this menu the function keys have a special function, as **▶** corresponds to the activation of the "UP" input, and **▲** corresponds to the activation of the "DOWN" input. The output value is displayed in %.

Activate **e** to leave the Front Setting menu and to store the present ramp value.

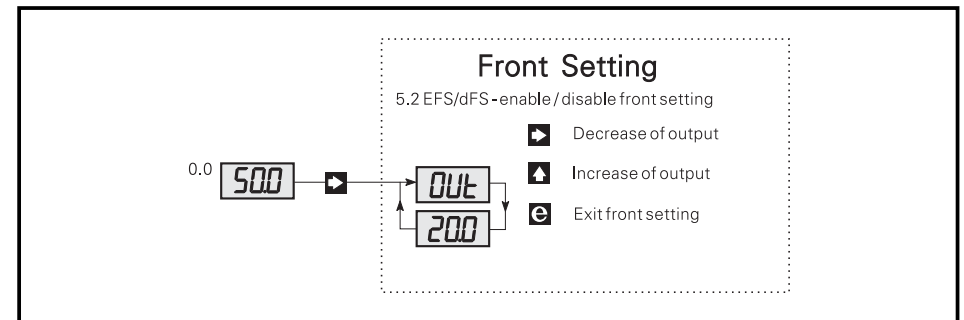

1.0 PAr - PARAMETER MENU - SELECTION OF POWER UP / RESET VALUE AND PRESCALER.

1.1 PUP - Setting of output value at Power up.

Selection of the function which the output will follow at Power up.

At HLd the output is set to the value it had immediately before power down. At rES the output is set to the present value of menu 1.2.

Possible selections are HLd - the memory value, and rES - the reset value.

1.2 rES - Setting of reset / preset value.

The reset value is set in % of the output span.

Valid selections are 0...99.9%.

1.3 PrE - Setting of prescaler for external pulses.

The prescaler is multiplied on the set up and down pulses. When the external pulse number is ≤ 60999 , the prescaler is set to 1.

Valid selections are 1...256.

2.0 UP - SETTING OF UP RAMPS.

When menu 5.1 = { 1 = Internal time measurement }, the up ramp is set in seconds and menu 1.3 (prescaler) has no function.

When menu 5.1 = { 2 = External pulses or 3 = 2-phase encoder }, the up ramp is set in number of pulses ≤ 60999 . The pre-scaler set in menu 1.3 is multiplied on the entered up pulses.

2.1 UHI - Setting of up ramps in thousands.

Valid selections are 0...999 (* 1000 s) or 0...60 (* 1000 pulses).

2.2 ULO - Setting of up ramps in ones.

Valid selections are 0...999 s or pulses.

3.0 dO - SETTING OF DOWN RAMPS.

When menu 5.1 = { 1 = Internal time measurement }, the down ramp is set in seconds and menu 1.3 (prescaler) has no function.

When menu 5.1 = { 2 = External pulses or 3 = 2-phase encoder }, the down ramp is set in number of pulses ≤ 60999 . The prescaler set in menu 1.3 is multiplied on the entered down pulses.

3.1 dHI - Setting of down ramps in thousands.

Valid selections are 0...999 (* 1000 s), or 0...60 (* 1000 pulses).

3.2 dLO - Setting of down ramps in ones.

Valid selections are 0...999 s or pulses.

4.0 Out - SETTING OF SIGNAL OUTPUT.

4.1 OL - Entry of 0% output signal.

Possible selections are current 0.0...20.0 mA, or voltage 0.0...10.0 VDC.

4.2 OH - Entry of 100% output signal.

Possible selections are current 0.0...20.0 mA, or voltage 0.0...10.0 VDC.

4.3 UI - Selection of current or voltage output.

The basic calibration data within the module varies according to the selected output signal range, which means that the current output is current-calibrated, and the voltage output is voltage-calibrated by way of the installed internal resistors.

See the hardware programming for correct jumper setting.

Possible selections are:

001 = current output in the range 0...10 mA

002 = current output in the range 0...20 mA

003 = voltage output in the range 0...500 mV

004 = voltage output in the range 0...1000 mV

005 = voltage output in the range 0...5 V

006 = voltage output in the range 0...10 V

4.4 OR Selection of Overrange.

If ON has been selected, the output can exceed the selected output span by $\pm 3\%$. However, only within 0 to 20.5 mA. If OFF has been selected, the output is limited by the selected output span.

Possible selections are ON or OFF.

5.0 APP - SELECTION OF APPLICATION.

5.1 FUn - Selection of function.

Common to all functions is the selection of filter (FLt) in menu 5.2. Depending on the selection, the up/down pulse length must be > 10 ms (50 Hz), or > 0.5 ms (1 kHz).

The reset input has a fixed filter of 30 ms (16 Hz).

At power up the output value can be set to adopt the value it had immediately before power down, or set to adopt the same value as at reset. The reset value can be set to a value between 0 and 99.9% of the output span.

POSSIBLE SELECTIONS OF FUNCTION ARE:

001 = Ramp generator with internal time measurement:

The up and down ramps can be set separately in the time range 0.1...999999 s. The up/down time measurement starts when the inputs have been activated longer than the time constant of the connected filter. If the up/down inputs are activated simultaneously, both ramp times will be measured and the output will decrease/increase by the difference between the times.

002 = RAMP GENERATOR WITH EXTERNAL PULSES:

The up and down ramps can be set separately by pulse numbers between 1 and 15,615,744 which are set in menu 2.0 UP/3.0 dO and menu 1.3 PrE respectively.

The values set in menu 2.0 and 3.0 (1...60999) are multiplied by the value set in menu 1.3 (1...256). An up ramp of 75258 pulses is set in menu 2.1 to 37; in menu 2.2 to 629; and in menu 1.3 to 2 (37629 x 2 = 75258). With a prescaler of 2, the number of pulses on the down ramp must also be set as (number of pulses / 2). The up/down pulses are detected when the inputs are activated longer than the time constant of the connected filter. If the up/down inputs are activated simultaneously, both input pulses will be read, and the output will increase/decrease by the difference between the pulses.

003 = RAMP GENERATOR FOR 2-PHASE ENCODER:

The resolution of the applied 2-phase encoder is doubled, as both the leading and trailing edges on the pulses are counted. A 2-phase encoder with 100 pulses per revolution which is to be revolved 10 times, must be set to 2000 pulses (100 x 10 x 2). The ramp pulses can be set with a pulse number between 1 and 15,615,744, which is set in menu 2.0 UP and 1.3 PrE respectively. Menu 3.0 has no function at a 2-phase encoder. The value set in menu 2.0 (1...60999) is multiplied by the value set in menu 1.3 (1...256). If the encoder yields 30000 pulses for instance, the ramp pulses must be set to 60000 by setting menu 2.1 to 60, menu 2.2 to 000, and menu 1.3 to 1 (60000 x 1 = 60000). The ramp pulses are detected when the inputs are activated longer than the time constant of the connected filter. When the encoder is turned in one direction, the output increases according to the set number of pulses. When the encoder is turned in the opposite direction, the output decreases accordingly. The output signal represents the encoder position and can be autocalibrated by activating the reset input. If the reset input is activated at for instance the 50% position of the encoder, the reset value must be set at 50%. Please note that as long as the reset inputs are active (> 30 ms), the output will adopt the set reset value.

5.2 EFS - Enable/disable Front Setting.

Access to change of ramp value is determined by the parameters EFS (Enable Front Setting) - change of ramp value is possible; or dFS (disable Front Setting) - locking of change of ramp value.

Possible selections are EFS or dFS.

5.3 FLt - Setting of up/down filter.

The filter can be set to a pulse length of > 10 ms (50Hz), or > 0.5 ms (1kHz).

Possible selections are LO - 50Hz, or HI 1 kHz.

5.4 PAS - Password.

When the password is 040, changes can be made in all menu points. When the password is <> 040, programming in all menu points is locked but open for reading of settings.

Possible selections are 0...999.

По вопросам продажи и поддержки обращайтесь:

Архангельск (8182)63-90-72
Астана (7172)727-132
Астрахань (8512)99-46-04
Барнаул (3852)73-04-60
Белгород (4722)40-23-64
Брянск (4832)59-03-52
Владивосток (423)249-28-31
Волгоград (844)278-03-48
Вологда (8172)26-41-59
Воронеж (473)204-51-73
Екатеринбург (343)384-55-89
Иваново (4932)77-34-06
Ижевск (3412)26-03-58
Казань (843)206-01-48

Калининград (4012)72-03-81
Калуга (4842)92-23-67
Кемерово (3842)65-04-62
Киров (8332)68-02-04
Краснодар (861)203-40-90
Красноярск (391)204-63-61
Курск (4712)77-13-04
Липецк (4742)52-20-81
Магнитогорск (3519)55-03-13
Москва (495)268-04-70
Мурманск (8152)59-64-93
Набережные Челны (8552)20-53-41
Нижний Новгород (831)429-08-12
Новокузнецк (3843)20-46-81

Новосибирск (383)227-86-73
Омск (3812)21-46-40
Орел (4862)44-53-42
Оренбург (3532)37-68-04
Пенза (8412)22-31-16
Пермь (342)205-81-47
Ростов-на-Дону (863)308-18-15
Рязань (4912)46-61-64
Самара (846)206-03-16
Санкт-Петербург (812)309-46-40
Саратов (845)249-38-78
Севастополь (8692)22-31-93
Симферополь (3652)67-13-56
Смоленск (4812)29-41-54

Сочи (862)225-72-31
Ставрополь (8652)20-65-13
Сургут (3462)77-98-35
Тверь (4822)63-31-35
Томск (3822)98-41-53
Тула (4872)74-02-29
Тюмень (3452)66-21-18
Ульяновск (8422)24-23-59
Уфа (347)229-48-12
Хабаровск (4212)92-98-04
Челябинск (351)202-03-61
Череповец (8202)49-02-64
Ярославль (4852)69-52-93

Единый адрес для всех регионов: pcn@nt-rt.ru || www.prelectronics.nt-rt.ru

