



2914 2-х проводной температурный преобразователь

Руководство по эксплуатации

Архангельск (8182)63-90-72
Астана (7172)727-132
Астрахань (8512)99-46-04
Барнаул (3852)73-04-60
Белгород (4722)40-23-64
Брянск (4832)59-03-52
Владивосток (423)249-28-31
Волгоград (844)278-03-48
Вологда (8172)26-41-59
Воронеж (473)204-51-73
Екатеринбург (343)384-55-89
Иваново (4932)77-34-06
Ижевск (3412)26-03-58
Казань (843)206-01-48

Калининград (4012)72-03-81
Калуга (4842)92-23-67
Кемерово (3842)65-04-62
Киров (8332)68-02-04
Краснодар (861)203-40-90
Красноярск (391)204-63-61
Курск (4712)77-13-04
Липецк (4742)52-20-81
Магнитогорск (3519)55-03-13
Москва (495)268-04-70
Мурманск (8152)59-64-93
Набережные Челны (8552)20-53-41
Нижний Новгород (831)429-08-12
Новокузнецк (3843)20-46-81

Новосибирск (383)227-86-73
Омск (3812)21-46-40
Орел (4862)44-53-42
Оренбург (3532)37-68-04
Пенза (8412)22-31-16
Пермь (342)205-81-47
Ростов-на-Дону (863)308-18-15
Рязань (4912)46-61-64
Самара (846)206-03-16
Санкт-Петербург (812)309-46-40
Саратов (845)249-38-78
Севастополь (8692)22-31-93
Симферополь (3652)67-13-56
Смоленск (4812)29-41-54

Сочи (862)225-72-31
Ставрополь (8652)20-65-13
Сургут (3462)77-98-35
Тверь (4822)63-31-35
Томск (3822)98-41-53
Тула (4872)74-02-29
Тюмень (3452)66-21-18
Ульяновск (8422)24-23-59
Уфа (347)229-48-12
Хабаровск (4212)92-98-04
Челябинск (351)202-03-61
Череповец (8202)49-02-64
Ярославль (4852)69-52-93

2-WIRE ROOM TEMPERATURE TRANSMITTER

Type 2914

CONTENTS

Declaration of Conformity	10
Application	11
Technical characteristics	11
Input	11
Output	12
Electrical specifications	12
Order	14
Block diagram	14
Mechanical specifications	15

DECLARATION OF CONFORMITY

As manufacturer

PR electronics A/S

hereby declares that the following product:

Type: 2914

Name: 2-wire room temperature transmitter

is in conformity with the following directives and standards:

The EMC Directive 2004/108/EC and later amendments

EN 61326-1

For specification of the acceptable EMC performance level, refer to the electrical specifications for the module.



Kim Rasmussen
Manufacturer's signature

2-WIRE ROOM TEMPERATURE TRANSMITTER 2914

- Room temperature measurement
- Complete with sensor and transmitter
- 4...20 mA output in 2-wire connection
- Easy mounting
- Measurement range 0...70°C
- Supply 8...35 VDC

APPLICATION:

Electronic temperature measurement in for instance control rooms, offices, heating plants, factories, living rooms, and similar dry rooms. Suitable as a transmitter for controllers, trip amplifiers, displays, or superior SCADA systems.

TECHNICAL CHARACTERISTICS:

The module is built around a microprocessor core with an efficient program operation. The basic calibration data and the present set-up are stored in an EEPROM thereby ensuring that the data is not lost or changed at power off. A precision Pt100 sensor with a small mass is mounted on the transmitter input thereby achieving a fast response time. The room temperature transmitter is protected against polarity reversal.

The front of the cabinet is made of white ABS plastic, the bottom is made of black PBT plastic. The bottom of the cabinet can be attached to a wall by two screws and the front is then clipped on to the bottom plate. Visible cable connection through a 10 mm cutout in the front of the cabinet. Covered cable connection through a 16 mm cutout in the bottom plate of the cabinet.

INPUT:

The input is mounted at the factory.

OUTPUT:

The 2-wire output signal of 4...20 mA is proportional and linear to the temperature value that influences the built-in sensor. The output signal represents the temperature range (span) to which the transmitter has been set up. A span of 0...50°C means that the output signal is 4 mA at 0°C and 20 mA at 50°C. The temperature range must be specified when ordering. A reversed output signal of 20...4 mA can be ordered. Also, a number of different sensor error detection methods are offered, for instance max. ≥ 23 mA.

ELECTRICAL SPECIFICATIONS - TYPE 2914:

Specifications range:

0°C to +70°C

Common specifications:

Supply voltage.....	8.0...35 VDC
Internal consumption	25 mW...0.8 W
Voltage drop	8 VDC
Warm-up time.....	5 min.
Signal / noise ratio	Min. 60 dB
Response time	10 s (@ 0,5 m/s)
Signal dynamics, input.....	17 bit
Signal dynamics, output.....	16 bit
Calibration temperature.....	20...28°C
Temperature coefficient.....	$< \pm 0.01^\circ\text{C}/^\circ\text{C}_{\text{amb}}$
Linearity error	$< \pm 0.1\%$ of span
Effect of supply voltage change.....	$\leq \pm 0.005\%$ of span / VDC
EMC immunity influence	$< \pm 0.5\%$ of span
Max. wire size.....	1 x 1.5 mm ²
Air humidity	$< 95\%$ RH (non cond.)
Dimensions (H x B x D).....	70 x 121 x 25 mm
Protection degree.....	IP30
Weight	95 g

Input:

Measurement range	0...70°C
Min. measurement range (span).....	25°C
Max. offset.....	50% of max.°C
Sensor current.....	> 0.2 mA, < 0.4 mA
Basic accuracy	$< \pm 0.3^\circ\text{C}$

Output:

Signal range	4...20 mA
Min. signal range.....	16 mA
Max. offset.....	20% of max. mA
Updating time.....	135 ms
Load resistance.....	$\leq (V_{\text{supply}} - 8) / 0.023 [\Omega]$
Load stability	$< \pm 0.01\%$ of span/100 Ω

Sensor error detection:

Please order exact value.....	3.5...23 mA
NAMUR NE43 Upscale	23 mA
NAMUR NE43 Downscale.....	3.5 mA
To max	≥ 23 mA
To min.....	≤ 3.8 mA
No function.....	Not defined

GOST R approval:

VNIIM

Observed authority requirements:

Standard:

EMC 2004/108/EC EN 61326-1

Of span = Of the presently selected range

ORDER:

Type	Measurement range	Output	Sensor error value
2914	0...50°C : A	Special : 0	To max., ≥ 23 mA : A
	0...70°C : B	4...20 mA : 2	To min., ≤ 3.8 mA : B
	Special : X	20...4 mA : 9	Special : X

BLOCK DIAGRAM:

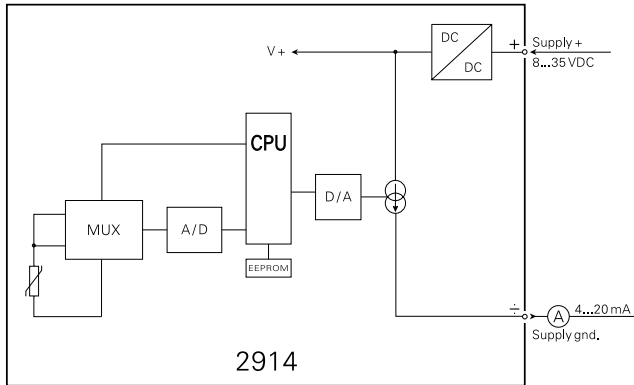

MECHANICAL SPECIFICATIONS:

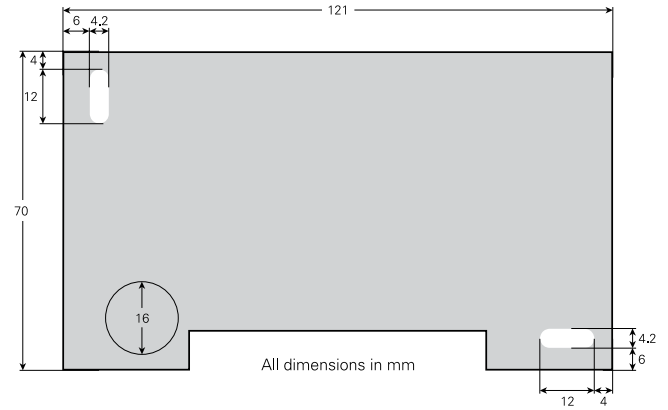

По вопросам продажи и поддержки обращайтесь:

Архангельск (8182)63-90-72
Астана (7172)727-132
Астрахань (8512)99-46-04
Барнаул (3852)73-04-60
Белгород (4722)40-23-64
Брянск (4832)59-03-52
Владивосток (423)249-28-31
Волгоград (844)278-03-48
Вологда (8172)26-41-59
Воронеж (473)204-51-73
Екатеринбург (343)384-55-89
Иваново (4932)77-34-06
Ижевск (3412)26-03-58
Казань (843)206-01-48

Калининград (4012)72-03-81
Калуга (4842)92-23-67
Кемерово (3842)65-04-62
Киров (8332)68-02-04
Краснодар (861)203-40-90
Красноярск (391)204-63-61
Курск (4712)77-13-04
Липецк (4742)52-20-81
Магнитогорск (3519)55-03-13
Москва (495)268-04-70
Мурманск (8152)59-64-93
Набережные Челны (8552)20-53-41
Нижегород (831)429-08-12
Новокузнецк (3843)20-46-81

Новосибирск (383)227-86-73
Омск (3812)21-46-40
Орел (4862)44-53-42
Оренбург (3532)37-68-04
Пенза (8412)22-31-16
Пермь (342)205-81-47
Ростов-на-Дону (863)308-18-15
Рязань (4912)46-61-64
Самара (846)206-03-16
Санкт-Петербург (812)309-46-40
Саратов (845)249-38-78
Севастополь (8692)22-31-93
Симферополь (3652)67-13-56
Смоленск (4812)29-41-54

Сочи (862)225-72-31
Ставрополь (8652)20-65-13
Сургут (3462)77-98-35
Тверь (4822)63-31-35
Томск (3822)98-41-53
Тула (4872)74-02-29
Тюмень (3452)66-21-18
Ульяновск (8422)24-23-59
Уфа (347)229-48-12
Хабаровск (4212)92-98-04
Челябинск (351)202-03-61
Череповец (8202)49-02-64
Ярославль (4852)69-52-93

Единый адрес для всех регионов: pcn@nt-rt.ru || www.prelectronics.nt-rt.ru

