

# PR



## 5102 RTD-преобразователь

### Руководство по эксплуатации

Архангельск (8182)63-90-72  
Астана (7172)727-132  
Астрахань (8512)99-46-04  
Барнаул (3852)73-04-60  
Белгород (4722)40-23-64  
Брянск (4832)59-03-52  
Владивосток (423)249-28-31  
Волгоград (844)278-03-48  
Вологда (8172)26-41-59  
Воронеж (473)204-51-73  
Екатеринбург (343)384-55-89  
Иваново (4932)77-34-06  
Ижевск (3412)26-03-58  
Казань (843)206-01-48

Калининград (4012)72-03-81  
Калуга (4842)92-23-67  
Кемерово (3842)65-04-62  
Киров (8332)68-02-04  
Краснодар (861)203-40-90  
Красноярск (391)204-63-61  
Курск (4712)77-13-04  
Липецк (4742)52-20-81  
Магнитогорск (3519)55-03-13  
Москва (495)268-04-70  
Мурманск (8152)59-64-93  
Набережные Челны (8552)20-53-41  
Нижний Новгород (831)429-08-12  
Новокузнецк (3843)20-46-81

Новосибирск (383)227-86-73  
Омск (3812)21-46-40  
Орел (4862)44-53-42  
Оренбург (3532)37-68-04  
Пенза (8412)22-31-16  
Пермь (342)205-81-47  
Ростов-на-Дону (863)308-18-15  
Рязань (4912)46-61-64  
Самара (846)206-03-16  
Санкт-Петербург (812)309-46-40  
Саратов (845)249-38-78  
Севастополь (8692)22-31-93  
Симферополь (3652)67-13-56  
Смоленск (4812)29-41-54

Сочи (862)225-72-31  
Ставрополь (8652)20-65-13  
Сургут (3462)77-98-35  
Тверь (4822)63-31-35  
Томск (3822)98-41-53  
Тула (4872)74-02-29  
Тюмень (3452)66-21-18  
Ульяновск (8422)24-23-59  
Уфа (347)229-48-12  
Хабаровск (4212)92-98-04  
Челябинск (351)202-03-61  
Череповец (8202)49-02-64  
Ярославль (4852)69-52-93

# RTD TRANSMITTER

## PRetrans type 5102

### TABLE OF CONTENTS

Declaration of Conformity . . . . .	10
Application. . . . .	11
Technical characteristics . . . . .	11
Input . . . . .	11
Output . . . . .	12
Electrical specifications. . . . .	12
Order . . . . .	14
Block diagram . . . . .	14
5102 connection to Loop Link . . . . .	15

# DECLARATION OF CONFORMITY

As manufacturer

**PR electronics A/S**

hereby declares that the following product:

**Type: 5102**

**Name: RTD transmitter**

is in conformity with the following directives and standards:

The EMC Directive 2004/108/EC and later amendments

**EN 61326-1**

For specification of the acceptable EMC performance level, refer to the electrical specifications for the module.



Peter Rasmussen  
Manufacturer's signature

# RTD TRANSMITTER 5102

- *Programmable via PC*
- *Input for Pt100, Ni100 or Ohm*
- *Linearised analogue output*
- *24 VDC supply*
- *1- or 2-channel version*
- *DIN rail mounting*

## APPLICATION:

Linearised temperature measurement with Pt100 or Ni100 sensor. Conversion of linear resistance change to standard analogue current / voltage signal from e.g. valves or linear movements with attached potentiometer. Signal simulator via externally mounted 10-turn potentiometer.

## TECHNICAL CHARACTERISTICS:

### General:

The transmitter may be configured to the requested signal type by means of a DOS-based PC with the configuration program PReset 5000 and the communications unit Loop Link. The configuration of the transmitter may be done without connection of supply voltage as the communications unit supplies the required power. The supply voltage is 24 VDC with the same reference point for supply, input and output ground. The sensor connection is always a 3-wire connection with cable compensation for up to 50  $\Omega$  in each wire. If a 2-wire connection is requested, pin 43 and 42 (channel 1) or 53 and 52 (channel 2) must be short-circuited in the connection plug (no cable compensation). Sensor error detection is as standard set to Upscale, Downscale or entered to special output value.

### INPUT:

Linearised Pt100 temperature input according to IEC 751 within the range -200...+850°C. Linearised Ni100 temperature input according to DIN 43760 within the range -50...+250°C. Linear resistance input within the range 0...10 k $\Omega$ . Min. span for the RTD input is 50°C, for linear resistance 30  $\Omega$ .

The RTD input can be delivered set up in multiples of the main type (e.g. Pt1000). The input can be reversed so that 0% e.g. is 150°C and 100% is 0°C.

**OUTPUT:**

The analogue output may be configured to any current within the range 0...20 mA or voltage within the range 0...10 VDC with a min. span of 5 mA or 250 mVDC with a max. offset of 50% of the actual max. value. Voltage signals are produced by short-circuiting pin 13 and 12 (channel 1) or 23 and 22 (channel 2) together with mounting a jumper for internal shunt resistance. For voltage signals within the range 0...1 VDC a 50 Ω shunt (JP1) is used, within the range 0...10 VDC a 500 Ω shunt (JP2) is used. The voltage signal is available between pin 12 and 11 (channel 1), or 22 and 21 (channel 2).

The min. load resistance for voltage signals is 500 kΩ.

**ELECTRICAL SPECIFICATIONS:****Specifications range:**

-20°C to +60°C

**Common specifications:**

Supply voltage ..... 19.2...28,8 VDC  
 Internal consumption ..... 1.7 W (2 channels)  
 Warm-up time..... < 5 min.  
 Communications interface ..... Loop Link  
 Signal / noise ratio ..... Min. 60 dB  
 Signal dynamics, input..... 17 bit  
 Signal dynamics, output . ..... 16 bit  
 Response time (0...90%, 100...10%) ..... < 165 ms  
 Calibration temperature ..... 20...28°C  
 Temperature coefficient..... < ±0.01% /°Camb.  
 Linearity error ..... < 0.1% of span  
 EMC immunity influence . ..... < ±0.5% of span  
 Screw terminal torsion . ..... 0.5 Nm  
 Relative air humidity . ..... < 95% RH (non-cond.)  
 Dimensions (HxWxD)..... 109 x 23.5 x 130 mm  
 DIN rail type..... DIN 46277  
 Protection degree..... IP20  
 Weight ..... 170 g

**Input:**

Type	Min. value	Max. value	Min. span	Standard
Pt100	-200°C	+850°C	50°C	IEC 751
Ni100	-50°C	+250°C	50°C	DIN 43760
Lin. R	0 Ω	10 kΩ	30 Ω	-----

Max. offset ..... 50% of selected max. value  
 Cable resistance per wire (prog.) . ..... Max. 10...50 Ω  
 Sensor current..... > 0.2, < 0.4 mA  
 Basic accuracy..... < ±0.3°C  
 Temp. coefficient for span <100°C ..... < ±0.01°C/°Camb.  
 Sensor error detection . ..... Upscale / Downscale / selected value

**Output:**

Signal range ..... 0...20 mA / 0...10 VDC  
 Min. signal range. .... 5 mA / 250 mV  
 Max. offset . ..... 50% of selected max. value  
 Load (max.)..... 20 mA / 600 Ω / 12 VDC  
 Load stability . ..... < 0.01% of span / 100 Ω  
 Current limit..... < 28 mA

**GOST R approval:**

VNIIM

**Observed authority requirements:**

EMC 2004/108/EC ..... EN 61326-1

**Standard:**

**Of span** = Of the presently selected range.

**ORDER:**

Type	Channels
5102	1 channel : A
	2 channels : B

**BLOCK DIAGRAM:**

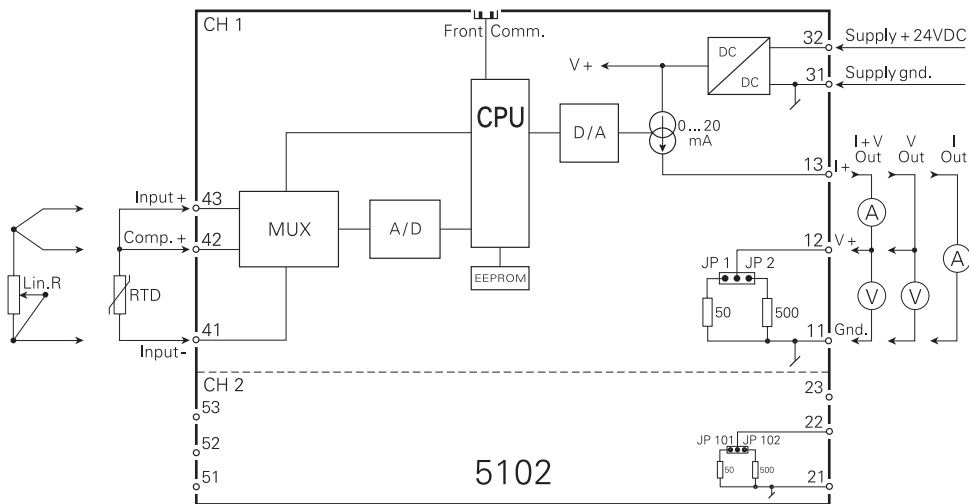

For 2-wire connection, short-circuit pin 42 and 43.

**5102 CONNECTION TO LOOP LINK:**

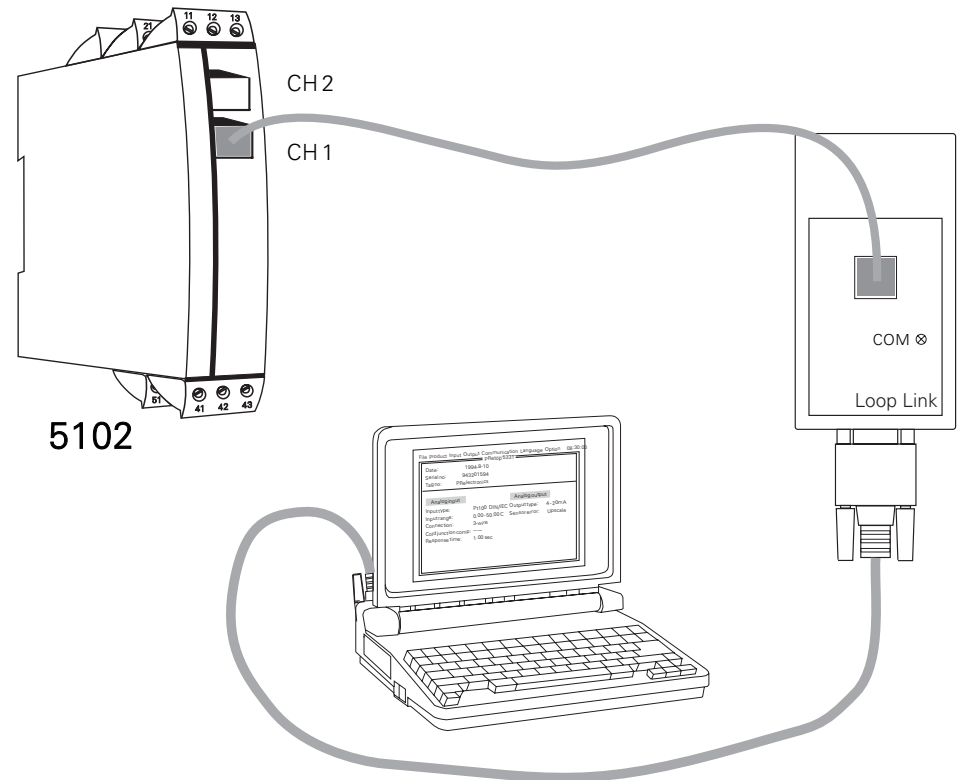

NB: The module can be programmed whether the supply is connected or disconnected. If the supply is connected during programming, the module must be disconnected and then reconnected after programming.

**По вопросам продажи и поддержки обращайтесь:**

**Архангельск** (8182)63-90-72  
**Астана** (7172)727-132  
**Астрахань** (8512)99-46-04  
**Барнаул** (3852)73-04-60  
**Белгород** (4722)40-23-64  
**Брянск** (4832)59-03-52  
**Владивосток** (423)249-28-31  
**Волгоград** (844)278-03-48  
**Вологда** (8172)26-41-59  
**Воронеж** (473)204-51-73  
**Екатеринбург** (343)384-55-89  
**Иваново** (4932)77-34-06  
**Ижевск** (3412)26-03-58  
**Казань** (843)206-01-48

**Калининград** (4012)72-03-81  
**Калуга** (4842)92-23-67  
**Кемерово** (3842)65-04-62  
**Киров** (8332)68-02-04  
**Краснодар** (861)203-40-90  
**Красноярск** (391)204-63-61  
**Курск** (4712)77-13-04  
**Липецк** (4742)52-20-81  
**Магнитогорск** (3519)55-03-13  
**Москва** (495)268-04-70  
**Мурманск** (8152)59-64-93  
**Набережные Челны** (8552)20-53-41  
**Нижний Новгород** (831)429-08-12  
**Новокузнецк** (3843)20-46-81

**Новосибирск** (383)227-86-73  
**Омск** (3812)21-46-40  
**Орел** (4862)44-53-42  
**Оренбург** (3532)37-68-04  
**Пенза** (8412)22-31-16  
**Пермь** (342)205-81-47  
**Ростов-на-Дону** (863)308-18-15  
**Рязань** (4912)46-61-64  
**Самара** (846)206-03-16  
**Санкт-Петербург** (812)309-46-40  
**Саратов** (845)249-38-78  
**Севастополь** (8692)22-31-93  
**Симферополь** (3652)67-13-56  
**Смоленск** (4812)29-41-54

**Сочи** (862)225-72-31  
**Ставрополь** (8652)20-65-13  
**Сургут** (3462)77-98-35  
**Тверь** (4822)63-31-35  
**Томск** (3822)98-41-53  
**Тула** (4872)74-02-29  
**Тюмень** (3452)66-21-18  
**Ульяновск** (8422)24-23-59  
**Уфа** (347)229-48-12  
**Хабаровск** (4212)92-98-04  
**Челябинск** (351)202-03-61  
**Череповец** (8202)49-02-64  
**Ярославль** (4852)69-52-93

**Единый адрес для всех регионов: [pcn@nt-rt.ru](mailto:pcn@nt-rt.ru) || [www.prelectronics.nt-rt.ru](http://www.prelectronics.nt-rt.ru)**

